

# CHERRY® G800 ERGONOMIC HAND RIVETER

## A NEW COMPACT, HIGH STRENGTH HAND POWERED RIVETER

The Cherry® G800 is an ergonomic, lightweight hand powered riveter capable of installing a wide variety of blind type fasteners. The all metal design makes this compact and robust tool ideal for use in rugged repair facilities and field repair. The exceptional power multiplication provides up to 6000 Lbs.

### FEATURES & BENEFITS

#### ergonomic design

- Lightweight with cushioned handle and adjustable lever span
- An internal shock absorber reduces operating shocks
- Smart power optimization system provides extremely high loads at low hand effort and increased productivity

#### versatile

- CherryMax® mounting system (same as G704B) compatible with our most popular pulling heads like H782, H781-456, H753A-456
- A full line of slim pulling heads available for a wide variety of blind fasteners

#### reliable

This product was subjected to extensive testing; its quality is backed by the Cherry® reputation for high quality tools. Your Cherry® tools remain the industry leader in after sales support.

#### economical

- It is built to last and to require minimum service. It features:
- High strength steel and aluminum construction
  - Leak proof design with advanced seals and built-in redundancies
  - Durable coatings for use in harsh environments

#### simple, cost-effective maintenance

- Safe & quick access to wear items (jaws, jaw follower)
- Visual fluid level indicator and easy to follow troubleshooting guide
- Service, repair, refill in just minutes; no special tools needed

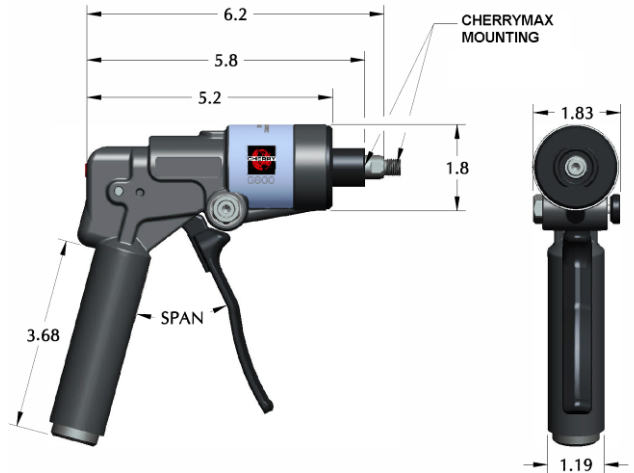

### TECHNICAL SPECIFICATIONS

STROKE	PULLING FORCE (adjustable)	POWER SOURCE	WEIGHT (WITHOUT PULLING HEAD)
3/4" min.	Up to 6000 lbs.	Hand Pump	1.7 lbs.

### KIT OPTIONS

- **G800CMR** – This battle damage repair kit includes the G800 riveter equipped with H800, a compact offset (H782), a right angle (H753A-456) pulling heads as well as 886-003 and 782-5BB nose pieces. Additionally, this kit includes a fastener reference guide, grip gauge, and tool documentation (tool manual, tool sheets)
- **ON-DEMAND KITS**- Other kits may be made available at request; please call CHERRY® to discuss your needs.
- **G800KS** – service kit: it includes all seals, screws, foam handle, ball bearings and springs.



1224 East Warner Ave, Santa Ana, CA 92705  
 Tel: 1-714-545-5511 Fax: 1-714-850-6093  
[www.cherryaerospace.com](http://www.cherryaerospace.com)  
 CA-1050, Rev – DCR 09-0956, 7-19-09



Supplier's Federal Identification Code: 11815

# CHERRY® G800 ERGONOMIC HAND RIVETER

A NEW COMPACT, HIGH STRENGTH HAND POWERED RIVETER

## PULLING HEAD SELECTION

Your hand riveter comes with H800 & 782-456; additional nose pieces and pulling heads may be purchased as needed. For Rivetless Nut Plate (RNP) installation, H704-( )NP (metallic structure) or H704-( )NPC (composite structure); see our tool sheets for more information. For installing other fasteners or RNP removal, call Cherry®; we will be happy to recommend the right configuration. Notes: Items in red, marked with an asterisk (\*) are standard components provided with the pulling heads.

MODEL NUMBER	JAW P/N	JAW FOLLOWER	NOSE PIECE	INSTALLS THE FOLLOWING PRODUCTS
 <p><b>H800</b></p>	*701B18	*753A14A	*782-456	CherryMAX, CherryMAX AB: -4, -5, -6 (except 6 Alum) Blindbolt "S" type: -04 & -05 MBC Lock Creator: -4, -5, -6 NAS1900 "U" type: -4 & -5
			886-003	CherryLOCK "A" Code: -3
			886-004	CherryLOCK "A" Code: -4
			886-005	CherryLOCK "A" Code: -5
 <p><b>RIGHT ANGLE: H753A-456</b> INSTALLS NAS1400 &amp; 1722 RIVETS UP TO -04 GRIP</p>	782-010	886-002	886-006	CherryLOCK "A" Code: -6
	*701B18	*753A14A	782-5BB	Blindbolt "U" Type: -05
			782-4MBC	Standard MBC: -4
			782-5MBC	Standard MBC: -5
	782-010	886-002	782-6MBC	Standard MBC: -6
			782 -6AL	CherryMAX "AB" -6 Alum, NAS1900 -4, -5, -6
	*701B18	*753A14A	782-3	3/32" SPR & -3 pull thru NP Rivets
			782-4NAS	NAS1900, -4 (no shift washer)
			782-5NAS	NAS1900, -5 (no shift washer)
	782-010	886-002	782-6NAS	NAS1900, -6 (no shift washer)

MODEL NUMBER	JAW P/N	NOSE PIECE	INSTALLS THE FOLLOWING PRODUCTS	
 <p><b>Offset: H782</b></p>	*701B18	*782-456	CherryMAX & CherryMAX AB: -4, -5 & -6 (except -6 Alum) Blindbolt "S" type: -04 & -05 MBC Lock Creator: -4, -5, -6 NAS1900 "U" type: -4 & -5	
		886-003	CherryLOCK "A" Code: -3	
		886-004	CherryLOCK "A" Code: -4	
		886-005	CherryLOCK "A" Code: -5	
	782-010	886-006	CherryLOCK "A" Code: -6	
	*701B18	886-002	782-5BB	Blindbolt "U" Type: -05
			782-4MBC	Standard MBC: -4
			782-5MBC	Standard MBC: -5
	782-010	886-002	782-6MBC	Standard MBC: -6
			782 -6AL	CherryMAX "AB" -6 Al; NAS1900 -4, -5 & -6
*701B18	886-002	782-3	3/32" SPR & -3 pull thru NP Rivets	
		782-4NAS	NAS1900, -4 (no shift washer)	
		782-5NAS	NAS1900, -5 (no shift washer)	
782-010	886-002	782-6NAS	NAS1900, -6 (no shift washer)	

MODEL NUMBER	JAW P/N	NOSE PIECE P/N	INSTALLS THE FOLLOWING PRODUCTS
 <p><b>HEAVY DUTY: HD800-8</b></p>	*652-043	*652-024	CherryMax, "A" Code, "AB" -8 (all materials)
		652-065	Maxibolt Plus -5, 6, 8
	865C25	652-035	Maxibolt -8 "S" type
		652-065	Maxibolt -8 "U" type
	744C76	652-038	Maxibolt -6 "S" type
		652-067	Maxibolt -6 "U" type



1224 East Warner Ave, Santa Ana, CA 92705  
Tel: 1-714-545-5511 Fax: 1-714-850-6093  
[www.cherryaerospace.com](http://www.cherryaerospace.com)  
CA-1050, Rev - DCR 09-0956, 7-19-09

Supplier's Federal Identification Code: 11815