

BROSSEUSE REVOLVER MAB 16



MODELE	:	MAB 16
VITESSE	:	18 000 tr/mn
PUISSANCE	:	0,6 kW
LONGUEUR	:	172 mm
HAUTEUR	:	112 mm
MASSE	:	0,9 kg
CONSOMMATION	:	400 l/mn
UTILISATION	:	Brosses M 14
RACCORD	:	1/4 GAZ Femelle
DIAMETRE INT. FLEXIBLE	:	10 mm

MAJ : 06.03
Vérif. : N.P.L
Appr. : C . P

Fabrication française OUTIPERRET



Matériel conforme à la D.E 89/392/CEE, aux Normes EN292-1 et 2, EN294, EN68, NFE75199,NFE65130

OPINDUS : 1, Rue Maurice Audibert 69800 SAINT PRIEST Tél : 04.78.21.73.14 - Fax : 04.78.21.73.01

BROSSEUSE REVOLVER



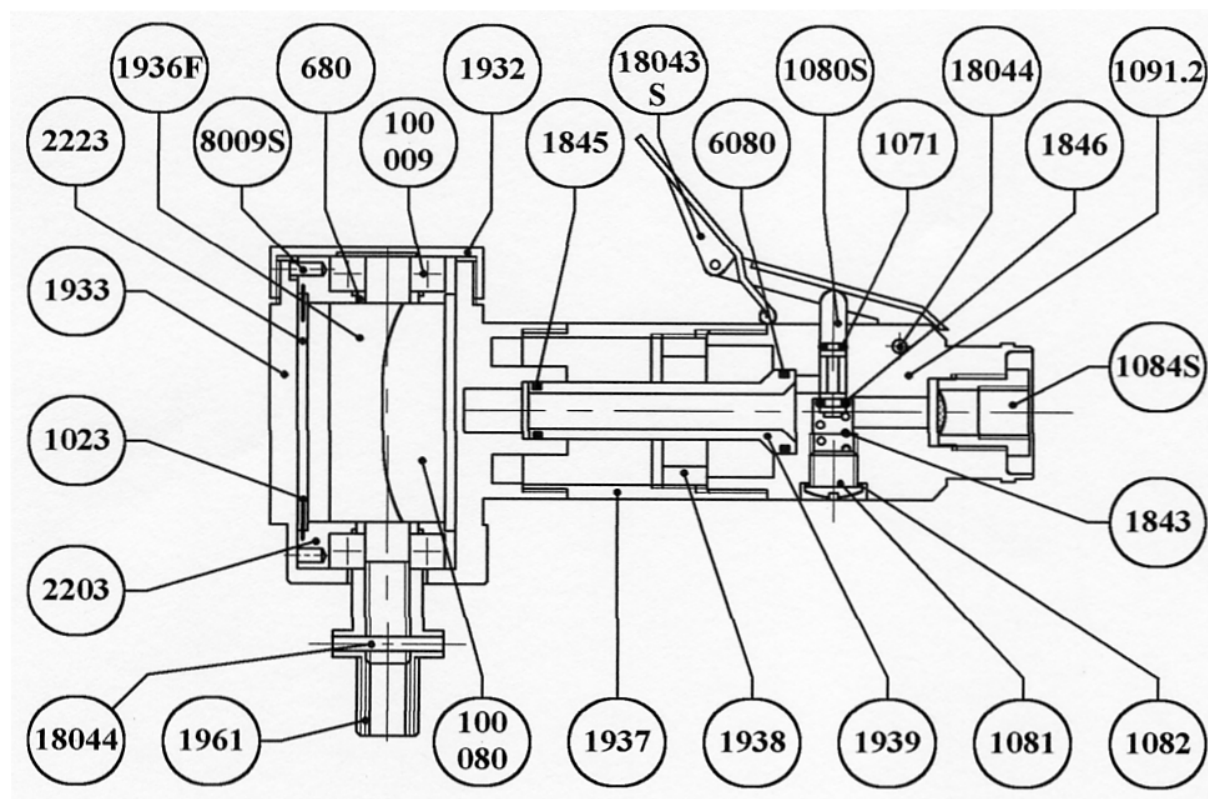

MAB 16



REFERENCE	NBRE	DESIGNATION
680	2	Entretoise
1023	2	Goupille
1071	1	Joint
1080 S	1	Soupape
1081	1	Bouchon
1082	1	Joint
1084 S	1	Raccord filtre F. 1/4''
1091-2	1	Poignée
1843	1	Ressort
1845	1	Joint
1846	1	Joint
1932	1	Ecrou moteur
1933	1	Corps

REFERENCE	NBRE	DESIGNATION
1936 F	1	Rotor
1937	1	Tube poignée
1938	1	Ecrou de réglage
1939	1	Tube alimentation
1961	1	Adaptateur M 14
2203	2	Flasque
2223	1	Stator
6080	1	Joint
8009 S	1	Goupille
18043 S	1	Gâchette de sécurité
18044	2	Axe de gâchette
100009	2	Roulement
100080	4	Palette

Utilisation : Brosse coupe à haute vitesse sur écrou M 14

MAJ : 06.03 Vérif. : N.P.L Appr. : C . P	Fabrication française OUTIPERRET	   
Matériel conforme à la D.E 89/392/CEE, aux Normes EN292-1 et 2, EN294, EN68, NFE75199,NFE65130		
OPINDUS : 1, Rue Maurice Audibert 69800 SAINT PRIEST Tél : 04.78.21.73.14 - Fax : 04.78.21.73.01		