

# MEULEUSE REVOLVER (PINCE Ø 6 mm)

## MAP 16



<b>MODELE</b>	:	<b>MAP 16</b>
<b>VITESSE</b>	:	<b>18 000 tr/mn</b>
<b>PUISSANCE</b>	:	<b>0,6 kW</b>
<b>LONGUEUR</b>	:	<b>172 mm</b>
<b>HAUTEUR</b>	:	<b>122 mm</b>
<b>MASSE</b>	:	<b>0,9 kg</b>
<b>CONSOMMATION</b>	:	<b>400 l/mn</b>
<b>UTILISATION</b>	:	<b>Pince Ø 6 mm</b>
<b>RACCORD</b>	:	<b>1/4 GAZ Femelle</b>
<b>DIAMETRE INT. FLEXIBLE</b>	:	<b>10 mm</b>

MAJ : 06.03  
Vérif. : N.P.L  
Appr. : C . P

**Fabrication française OUTIPERRET**



Matériel conforme à la D.E 89/392/CEE, aux Normes EN292-1 et 2, EN294, EN68, NFE75199,NFE65130

**OPINDUS** : 1, Rue Maurice Audibert 69800 SAINT PRIEST Tél : 04.78.21.73.14 - Fax : 04.78.21.73.01

# MEULEUSE REVOLVER (PINCE Ø 6 mm)

## MAP 16

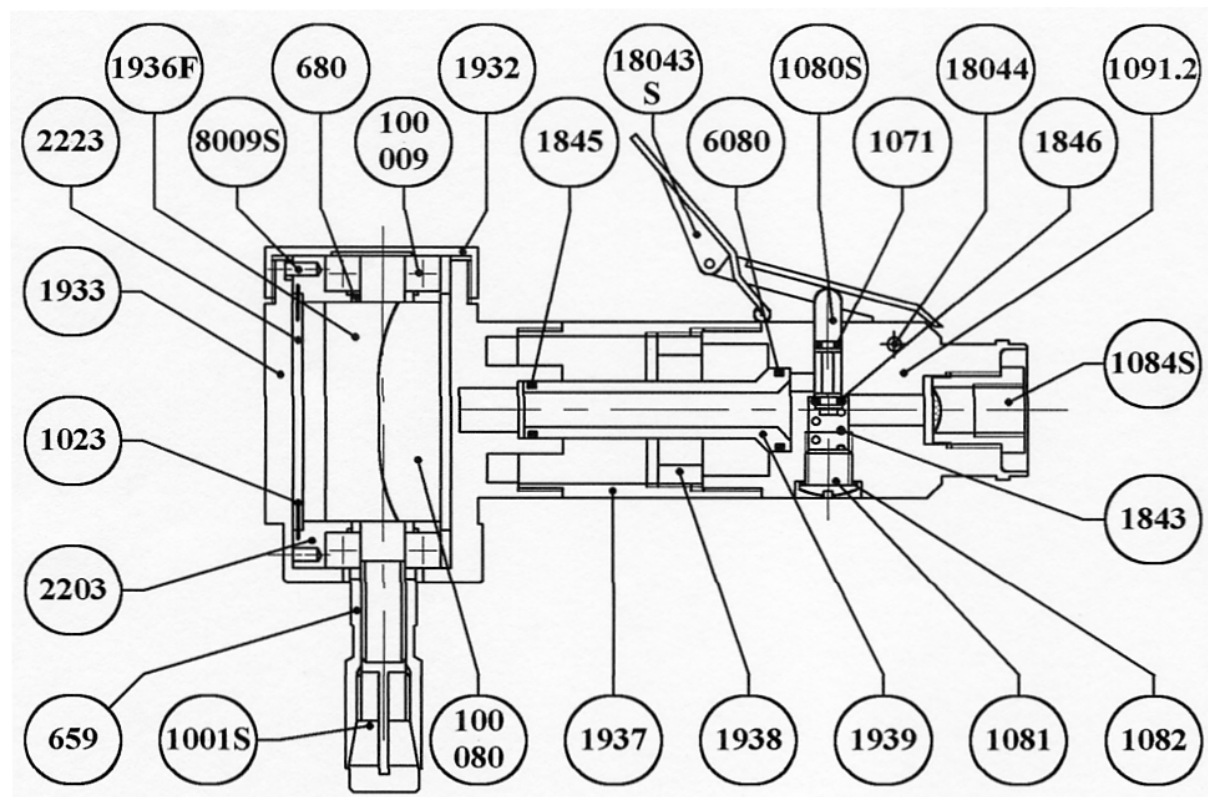

REFERENCE	NBRE	DESIGNATION
659	1	Nez porte pince
680	3	Entretoise
1001 S	1	Pince Ø 6 mm standard
1023	2	Goupille
1071	1	Joint
1080 S	1	Soupape
1081	1	Bouchon
1082	1	Joint
1084 S	1	Raccord filtre F. 1/4''
1091-2	1	Poignée
1843	1	Ressort
1845	1	Joint
1846	1	Joint
1932	1	Ecrou moteur

REFERENCE	NBRE	DESIGNATION
1933	1	Corps
1936 F	1	Rotor
1937	1	Tube poignée
1938	1	Ecrou de réglage
1939	1	Tube alimentation
2203	2	Flasque
2223	1	Stator
6080	1	Joint
8009 S	1	Goupille
18043 S	1	Gâchette de sécurité
18044	1	Axe de gâchette
100009	2	Roulement
100080	4	Palette

MAJ : 06.03  
Vérif. : N.P.L  
Appr. : C . P

**Fabrication française OUTIPERRET**



Matériel conforme à la D.E 89/392/CEE, aux Normes EN292-1 et 2, EN294, EN68, NFE75199,NFE65130

**OPINDUS** : 1, Rue Maurice Audibert 69800 SAINT PRIEST Tél : 04.78.21.73.14 - Fax : 04.78.21.73.01